



I-VALO PRO LED & SOLLINE LED

FI

Asennusohjeet

SV

Installationsinstruktioner

EN

Installation instructions



ta 25°C

IP20

220-240V
50/60 Hz

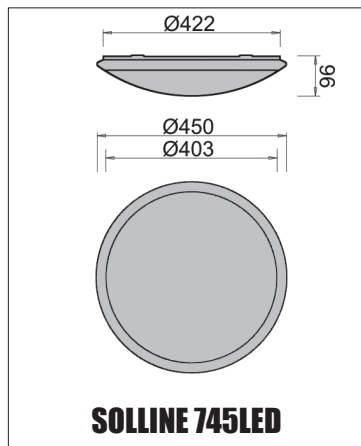
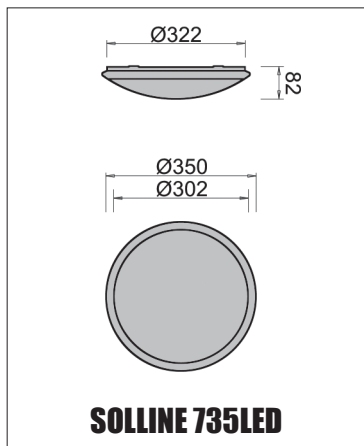
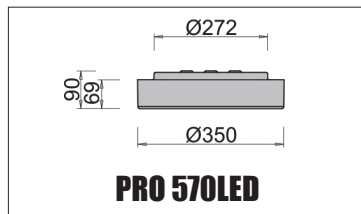
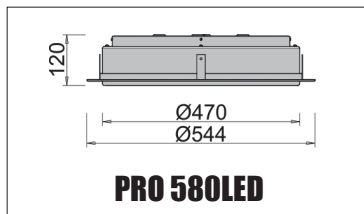
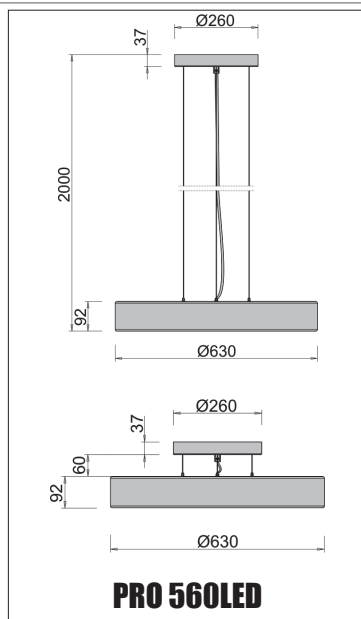
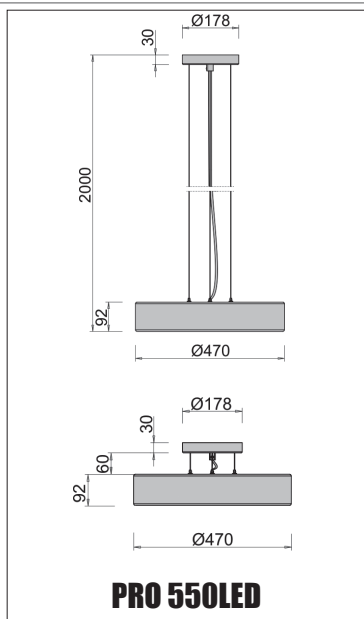



PRO LED -RIIPPUVALAISIMET
 PRO LED -PENDELARMATURER
 PRO LED - PENDANT LUMINAIRES

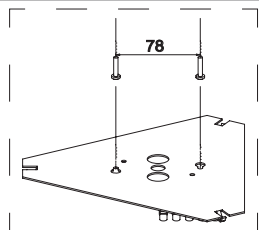

FI

ASENNUS

- Asenna kolmiolevy (1)
- Ripusta vaijerilenkit (2) kolmiolevyn koukkuihin
- Säädä vaijereilla sopiva asennuskorkeus vetämällä vaijereita vaijerilukon (3) läpi. Tarvittaessa leikkaa ylimääräinen vaijeri poikki
- Kytke liitosjohto (4)
- Kytkeyhmäjohdot
- Nosta kattokuppi (5) paikoilleen ja kiristä vedonpoistajalla

SV

MONTERING

- Montera den triangulära skivan (1)
- Träd vajrarnas öglor (2) på den triangulära skivans krokar
- Justera lämplig installationshöjd genom att dra vajrarna genom friktionslåset (3). Kapa överflödiga vajer vid behov
- Koppla anslutningsladdan (4)
- Koppla gruppledningarna
- För armaturkåpan (5) på plats och spänn fast med hjälp av dragavlastaren

EN

INSTALLATION

- Install the triangular plate (1).
- Hang the cable loops (2) from hooks in the triangular plate.
- Adjust the installation height by means of cables, pulling the cables through the cable lock (3). Cut the excess cable if necessary.
- Connect the connection wire (4).
- Connect the group wires.
- Lift the canopy (5) in place and tighten with a strain reliever.

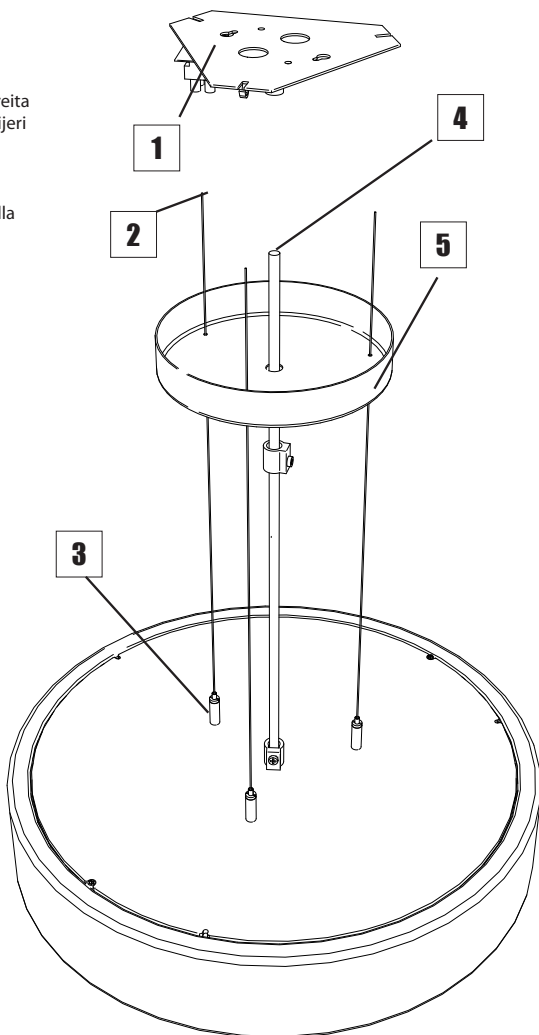



ta 25°C

IP20

220-240V
50/60 Hz



PRO LED -SEINÄ- JA KATTOVALAISIN
PRO LED -VÄGG- OCH TAKARMATUR
PRO LED -WALL OCH CEILING LUMINAIRE

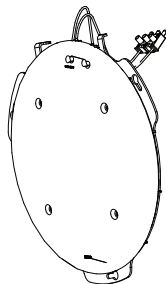
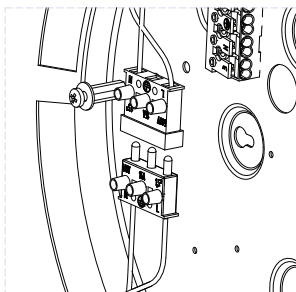

FI

ASENNUS

- Pinta-asennus kattoon tai seinään
- Kiinnitys pohjan avainreikästä, väli 78mm
- Kytke ryhmäjohtot, johtojen läpivienti pohjassa
- Kytke LED-moduuli pikaliittimellä niin, että liitin on kunnolla pohjassa
- Paina LED-moduuli kiinni kannaketappeihin, kierrä ja lukitse ruuvit
- Kiinnitä kehys paikoilleen

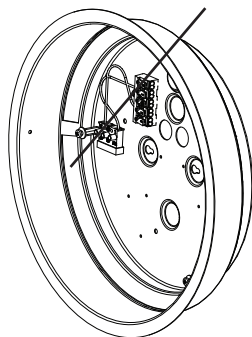

SV

MONTERING

- Ytmontering för tak eller vägg
- Fastsättning genom nyckelhålen i botten delen, hålavstånd 78 mm
- Koppla gruppledningarna, ledningsinföring via botten
- Anslut LED-modulen med snabbkopplingen och se till att kopplingen botten ordentligt
- Tryck LED-modulen mot stödtapparna, vrid den på plats och lås skruvarna
- Fäst ramen på plats

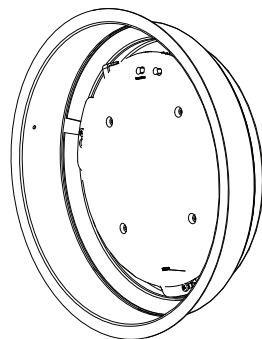

EN

INSTALLATION

- Surface-mounted on the ceiling or a wall
- Fix through the keyhole slots in the base, spacing 78mm
- Connect the group wires, the leadthrough for the wires is in the base
- Connect the LED module with a quick coupling so that the coupling remains properly on the base
- Press the LED module to the holding brackets, turn and lock the screws
- Fix the frame to its position



PRO LED UPPOVALAISIMET / PRO LED INFÄLLD ARMATUR / PRO LED RECESSED LUMINAIRES

FI

ASENNUS

- Uputusaukon halkaisija 495mm
- Uputussyvyys 40-130mm, upotussyvyydellä 120mm valaisimen alapinta katon tasalla
- Uputuskaulus (1) kiinnitetään kattolevyyn tai upotusaukon reunoihin
- Valaisimen pohja (2) kiinnitetään halutulle syvyydelle upotusaukon keskelle (avaimenreikä väli 78mm) Pohjaa asennettaessa varottava koskemasta ledien pintaan.
- Kytke ryhmäjohdot
- Kehys (3) kiinnitetään pohjaan oikeakätisellä bajonetti-kiinnityksellä

SV

MONTERING

- Inbyggnadsöppningens diameter 495 mm
- Inbyggnadsdjup 40-130 mm, vid inbyggnadsdjup 120 mm är belysningsarmaturens nedre yta i nivå med taket
- Inbyggnadsramen (1) fästs i taksivan eller i öppningens kanter
- Armaturens botten (2) fästs på önskat djup och centrerat i öppningen (nyckelhålens avstånd 78 mm). Ge akt på att inte röra vid led-dioderna då du monterar bottendelen.
- Koppla gruppledningarna
- Ramen (3) fästs vid bottendelen med högergående bajonettfattning

EN

INSTALLATION

- Recess diameter 495mm
- Recess depth 40-130mm, at recess depth 120mm the lower surface of the luminaire is flush with ceiling
- Recess flange (1) is fixed to the ceiling board or to the edges of the recess
- The base (2) of the luminaire is fixed at the desired depth, in the centre of the recess (spacing between keyhole slots 78 mm). Avoid contact with the LEDs during base installation.
- Connect the group wires
- The frame (3) is fixed to the base by means of a right-hand bayonet mount

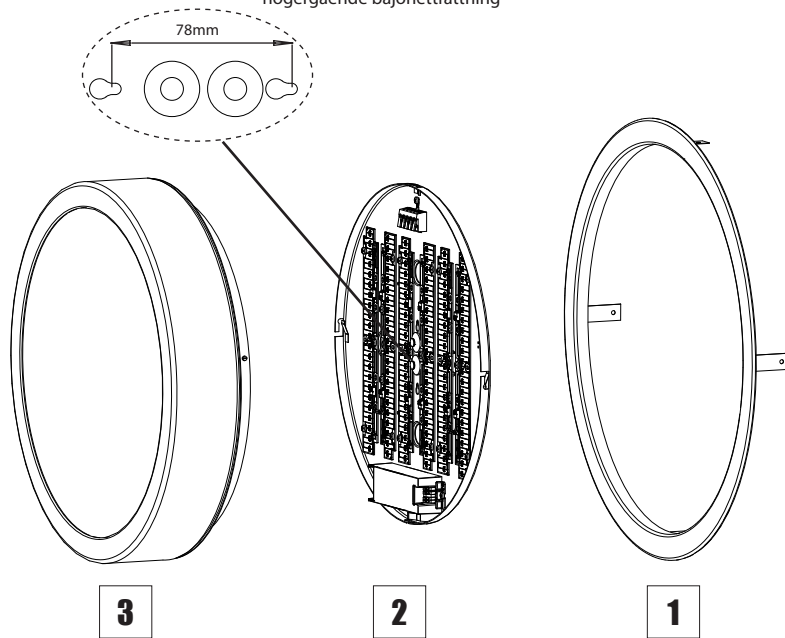



SOLLINE 735LED

FI

ASENNUS

- Pinta-asennus kattoon tai seinään
- Kiinnitys pohjan avainreistä, väli 78mm
- Kytke ryhmäjohdot, johtojen läpivienti pohjassa
- Kytke LED-moduuli pikaliittimellä niin, että liitin on kunnolla pohjassa
- Paina LED-moduuli kiinni kannaketappeihin, kierrä ja lukitse ruuvit
- Kehys kiinnitetään pohjaan oikeakätisellä bajonetti-kiinnityksellä

SV

MONTERING

- Ytmontering för tak eller vägg
- Fastsättning genom nyckelhålen i bottendelen, hålavstånd 78 mm
- Koppla gruppledningarna, ledningsinföring via botten
- Anslut LED-modulen med snabbkopplingen och se till att kopplingen bottnar ordentligt
- Tryck LED-modulen mot stödtapparna, vrid fast och lås skruvarna
- Ramen fästs vid bottendelen med högergående bajonettfättning

EN

INSTALLATION

- Surface-mounted on the ceiling or a wall
- Fix through the keyhole slots in the base, spacing 78mm
- Connect the group wires, the leadthrough for the wires is in the base
- Connect the LED module with a quick coupling so that the coupling remains properly on the base
- Press the LED module to the holding brackets, turn and lock the screws
- The frame is fixed to the base by means of a right-hand bayonet mount

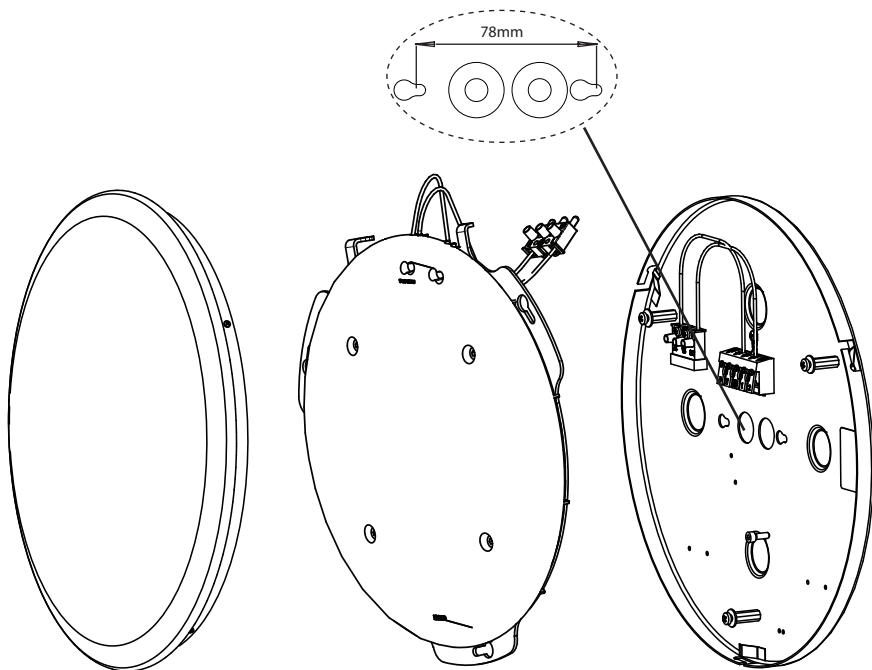

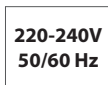

SOLLINE 745LED

FI

ASENNUS

- Pinta-asennus kattoon tai seinään
- Kiinnitys pohjan avainreikästä, väli 78mm Asennettaessa varottava koskemasta ledien pintaan
- Kytke ryhmäjohdot, johtojen läpivienvi pohjassa
- Kehys kiinnitetään pohjaan oikeakätisellä bajonetti-kiinnityksellä

SV

MONTERING

- Ytmontering för tak eller vägg
- Fastsättning genom nyckelhålen i bottendelen, hålavstånd 78 mm Ge akt på att inte röra vid led-dioderna under monteringen
- Koppla gruppledningarna, ledningsinföring via botten
- Ramen fästs vid bottendelen med högergående bajonettfättning

EN

INSTALLATION

- Surface-mounted on the ceiling or a wall
- Fix through the keyhole slots in the base, spacing 78mm. Avoid contact with the LEDs during installation
- Connect the group wires, the leadthrough for the wires is in the base
- The frame is fixed to the base by means of a right-hand bayonet mount

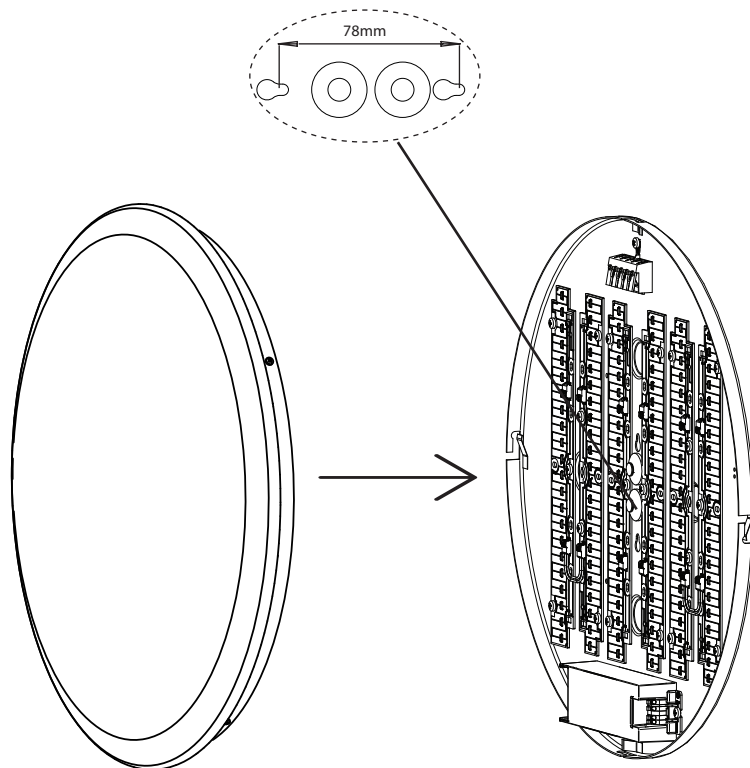



VALO
makes the world brighter.

I-VALO OY
14500 IITTALA
FINLAND
Tel. 010 501 3000

www.i-valo.com



Intertek



Intertek