

Battery Range Summary



As the cost of electrical energy continues to rise and as energy consumption in applications such as data centres continues to grow, energy efficiency has become a topic of rising interest and concern for the UPS industry.

Furthermore, the increasing awareness of the impact of energy consumption on the environment has put additional pressure on decision makers to develop genuine power management strategies and to invest in eco-friendly initiatives. As a result, reducing power usage through green initiatives has now become a critical objective for many UPS players who have tried to respond by developing higher efficiency power management systems in order to reduce energy losses and ultimately operating costs.

Features & Benefits

- **Wide Wpc range of front and top terminal monoblocs**
- **Specifically designed for high-rate discharge applications**
- **Excellent power density**
- **Long design life: 12+ years at 20°C**
- **Low energy consumption**
- **Low total cost of ownership**

EnerSys[®], one of the world's largest industrial battery manufacturers and a leader in stored energy solutions, is proud to be doing its part by developing the most effective and innovative products for a wide range of applications. EnerSys' DataSafe[®] HX Plus range of Valve Regulated Lead Acid (VRLA) batteries can significantly contribute to helping customers ultimately achieve their business goals in mission-critical power back-up applications. Using proven and advanced Thin Plate Pure Lead Technology (TPPL), combined with the selection of high grade, high purity materials enables EnerSys to deliver products with outstanding features and benefits and ultimately excellent value for money.

Construction

- High performance positive plates designed for long life and efficient recharge
- Negative plates provide perfect balance with the positive plates to ensure optimum recombination efficiency
- Low resistance microporous absorbed glass mat (AGM) separator. The electrolyte is absorbed within this material, preventing acid leakage in case of accidental damage
- High grade dilute sulphuric acid absorbed into separator material
- Containers and lids in highly resistant ABS polymer.
UL94 V-0 flame retardant option available⁽¹⁾
- High integrity dual-seal terminal design to ensure leak-free operation
- Self-resealing, low pressure non-return valve prevents ingress of atmospheric oxygen, with flame-arresting vents

Installation & Operation

- Monoblocs are designed for installation in cabinets or on stands, close to the point of use. A separate battery room is not necessary
- It is recommended that DataSafe® HX+ monoblocs are installed on their base. Please consult your EnerSys representative about any other installation orientations
- Recommended float charge voltage: 2.29Vpc at 20°C/2.27Vpc at 25°C
- Up to 24 month shelf life (at 20°C)
- Low maintenance: no water addition required
- Operating temperature range: -30°C to +45°C

Standards

- Tested according to international standard IEC 60896-21 and compliant to defined requirements of IEC 60896-22
- Classified as “Very long life” (>12 years) according to Eurobat Guide
- UL recognised component
- Batteries must be installed in accordance with the IEC 62485-2 standard and local/national regulations
- Classified as non-spillable battery and approved as non-hazardous cargo for land, sea and air transportation in accordance with the requirements of ADR/RID, IMDG and IATA respectively
- The management systems governing the manufacture of DataSafe® HX+ products are ISO 9001, ISO 14001 and ISO 45001 certified

General Specifications

Battery Type ⁽¹⁾	Nominal Voltage (V)	Watts/Cell (Wpc)		Nominal Dimensions (mm)			Typical Weight (kg)	Short Circuit Current (A) ⁽³⁾	Internal Resistance (mΩ) ⁽³⁾	Terminals
		15min to 1.67Vpc @ 25°C	C10 rate to 1.80Vpc @ 20°C	Length	Width	Overall Height ⁽²⁾				
12HX385+	12	386	87	302	175	227	30.2	2447	4.10	M6 F
12HX450+	12	450	101	302	175	227	32.5	2700	3.80	M6 F
12HX530+	12	530	124	338	173	273	40.8	3500	3.50	M6 F
12HX600+	12	601	139	338	173	273	43.2	3800	3.30	M6 F
12HX650F-FR+	12	650	163	561	125	283	52.0	3679	3.43	M6 M
12HX700F-FR+	12	701	169	561	125	316	59.6	3970	3.17	M6 M

Note:

⁽¹⁾ Add “FR” prior to the “+” of the Battery Type for flame retardant versions, eg. “12HX385FR+”. Note, Front Terminal (F) monoblocs are only available as UL94-V0 flame retardant version.

⁽²⁾ Height includes terminal.

⁽³⁾ Figures obtained via IEC method.

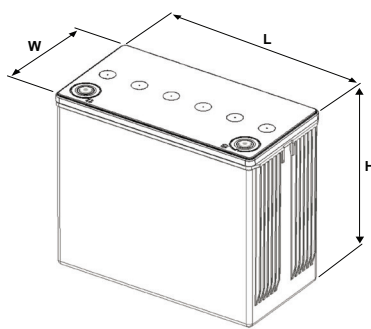

12HX385+
12HX450+
12HX530+
12HX600+

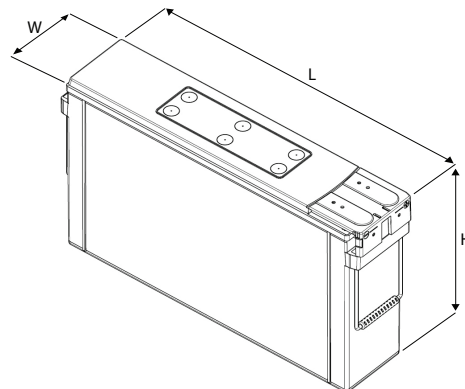

12HX650F-FR+
12HX700F-FR+



EnerSys World Headquarters
2366 Bernville Road
Reading, PA 19605, USA
Tel: +1-610-208-1991 /
+1-800-538-3627

EnerSys EMEA
EH Europe GmbH
Baarerstrasse 18
6300 Zug
Switzerland

EnerSys Asia
152 Beach Road
Gateway East Building #11-08
Singapore 189721
Tel: +65 6416 4800

Contact: